



# SCANWILL FLUID POWER – UNIQUE HYDRAULIC PRESSURE INTENSIFIER SOLUTIONS

Sales & Marketing Manager, Anders Levinsen



# SCANWILL FLUID POWER APS – FACTS & FIGURES

September 15

- Founded and localized in Denmark in 2001 by Jesper Will Iversen
- Launched the range of hydraulic pressure intensifiers in 2002
- A privately-owned company by MD Jesper Will Iversen
- Today five employees in Scanwill Fluid Power ApS
- Manufacturing of all parts is outsourced by sub suppliers
- Production and office facilities located in Albertslund – Copenhagen
- Quality management: ISO 9001 certificated



# DO YOU KNOW WHAT A SCANWILL INTENSIFIER DOES?

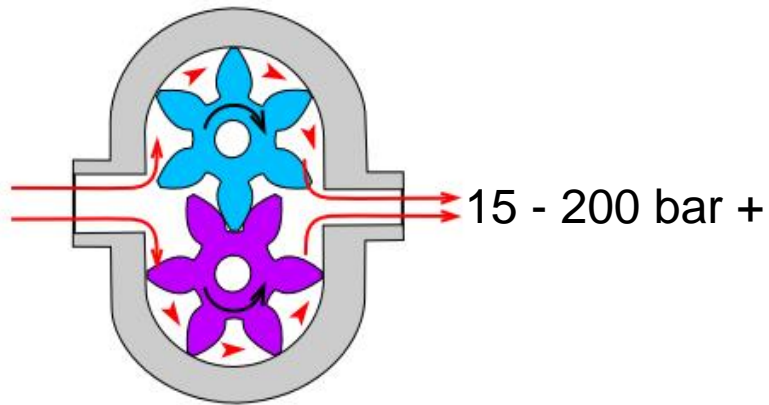

**$\Rightarrow$  22.5 – 4,000 bar**

The Scanwill intensifier increases a supplied pressure to a higher output pressure!

# HOW CAN WE ACHIEVE A HIGH PRESSURE?

Most Commonly Used Solution:  
Standard High Pressure Pump

POWER PACK WITH HIGH PRESSURE PUMP:

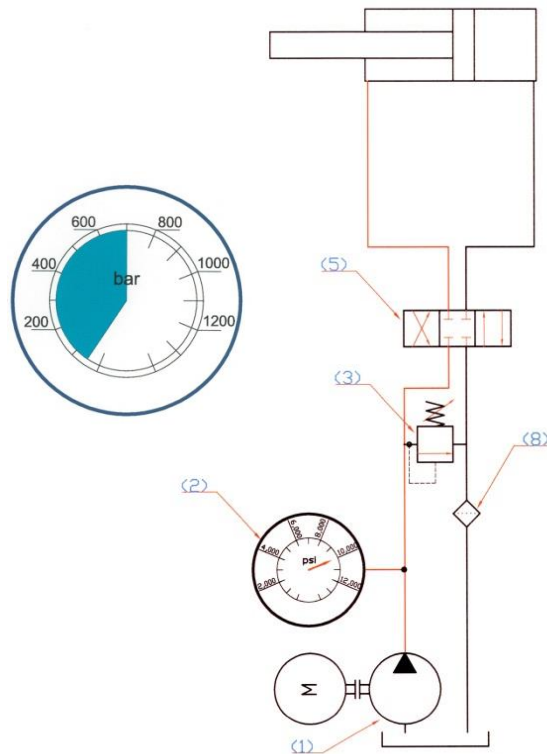

The Future Energy Saving Solution:  
Scanwill Pressure Intensifier

POWER PACK WITH low PRESSURE PUMP & INTENSIFIER:

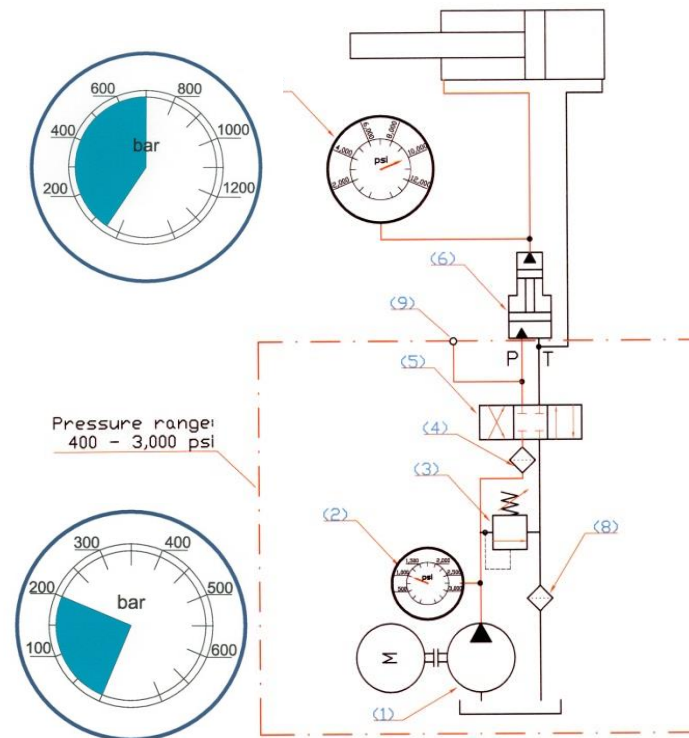

# THE BASIC PRINCIPLE OF A SCANWILL INTENSIFIER

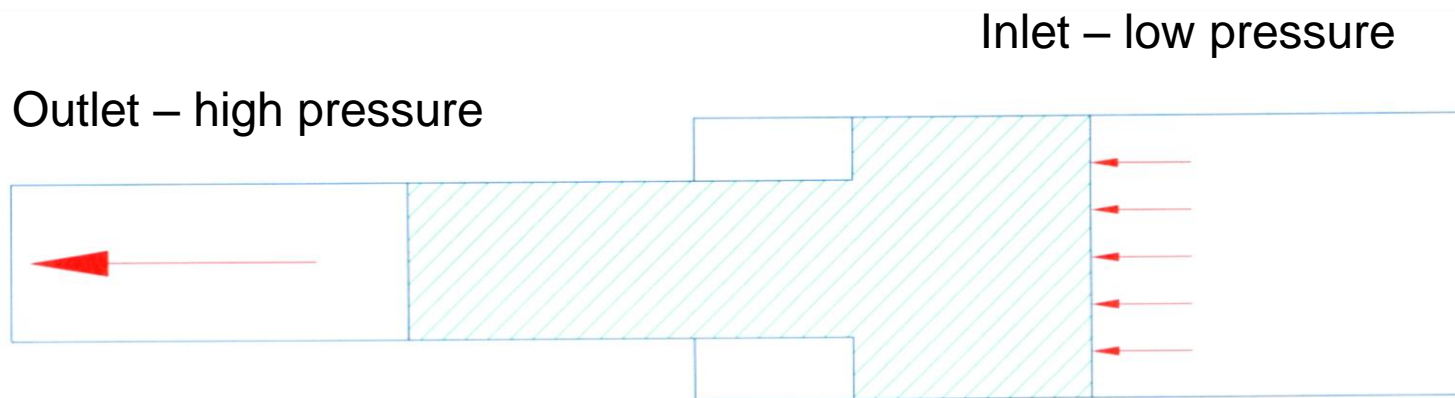

The intensifier function as a small “piston pump” in the system and will constantly deliver flow until the output pressure has been reached.

# SCANWILL ADDED VALVES AND MADE A COMPACT DESIGN

September 15

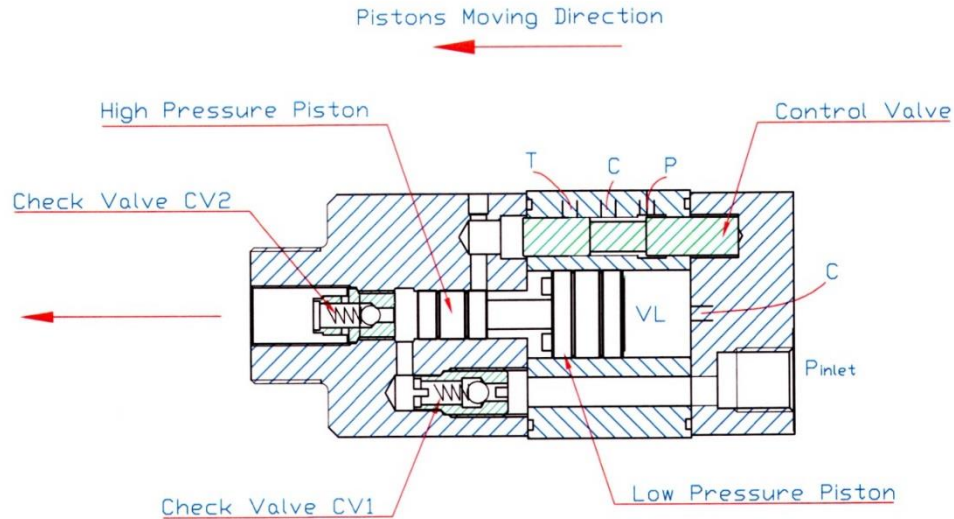

Piston speed up to 20 Hz.  
Hydraulically controlled only!

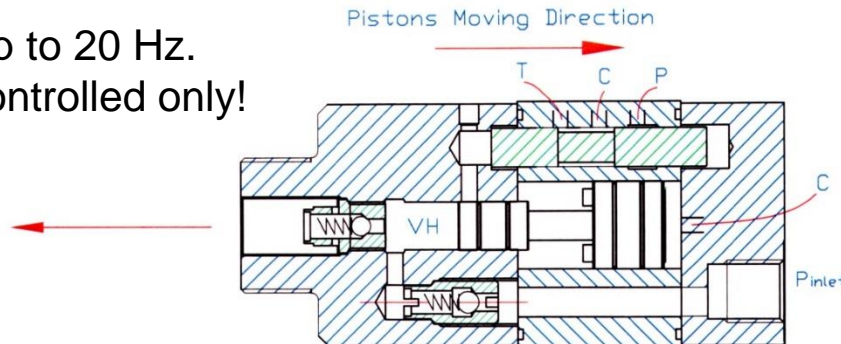

# THE BASIC PRINCIPLE & THE GENERAL FLOW-PRESSURE CURVE

September 15

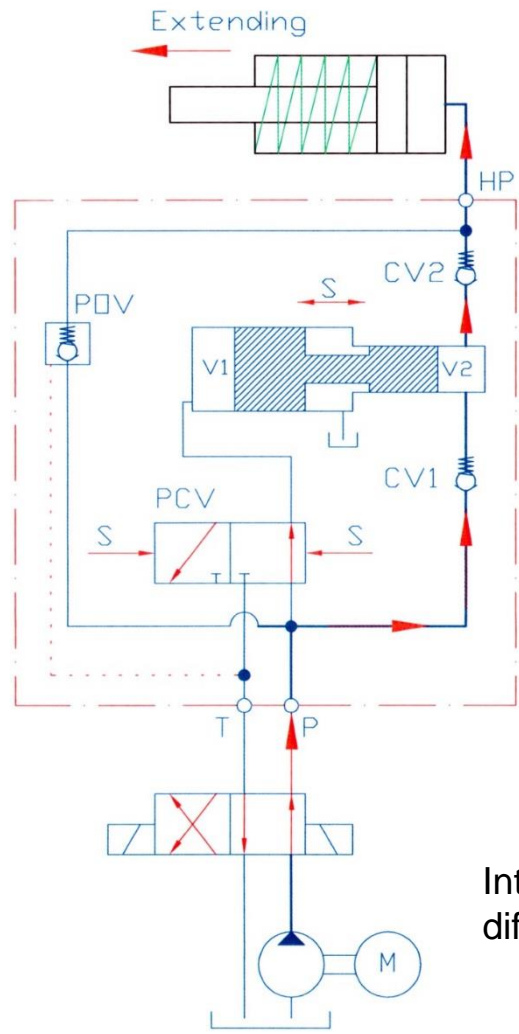

Add-on feature from intensifier!

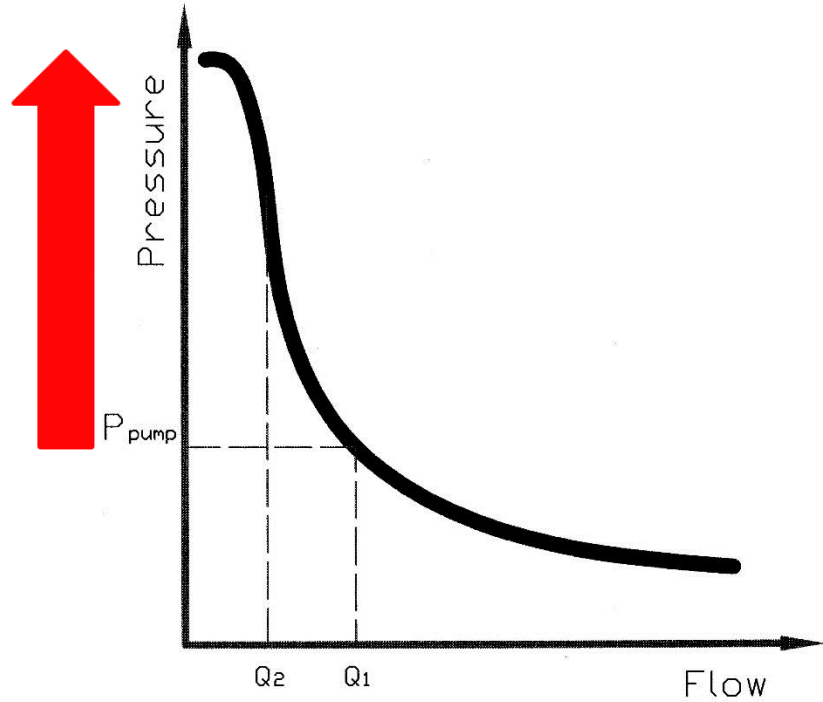

Intensifier output pressure equals ratio multiplied by the differential pressure between P & T (P minus T)!

# THE EXTENDING & RETRACTING CYCLE OF SCANWILL INTENSIFIERS

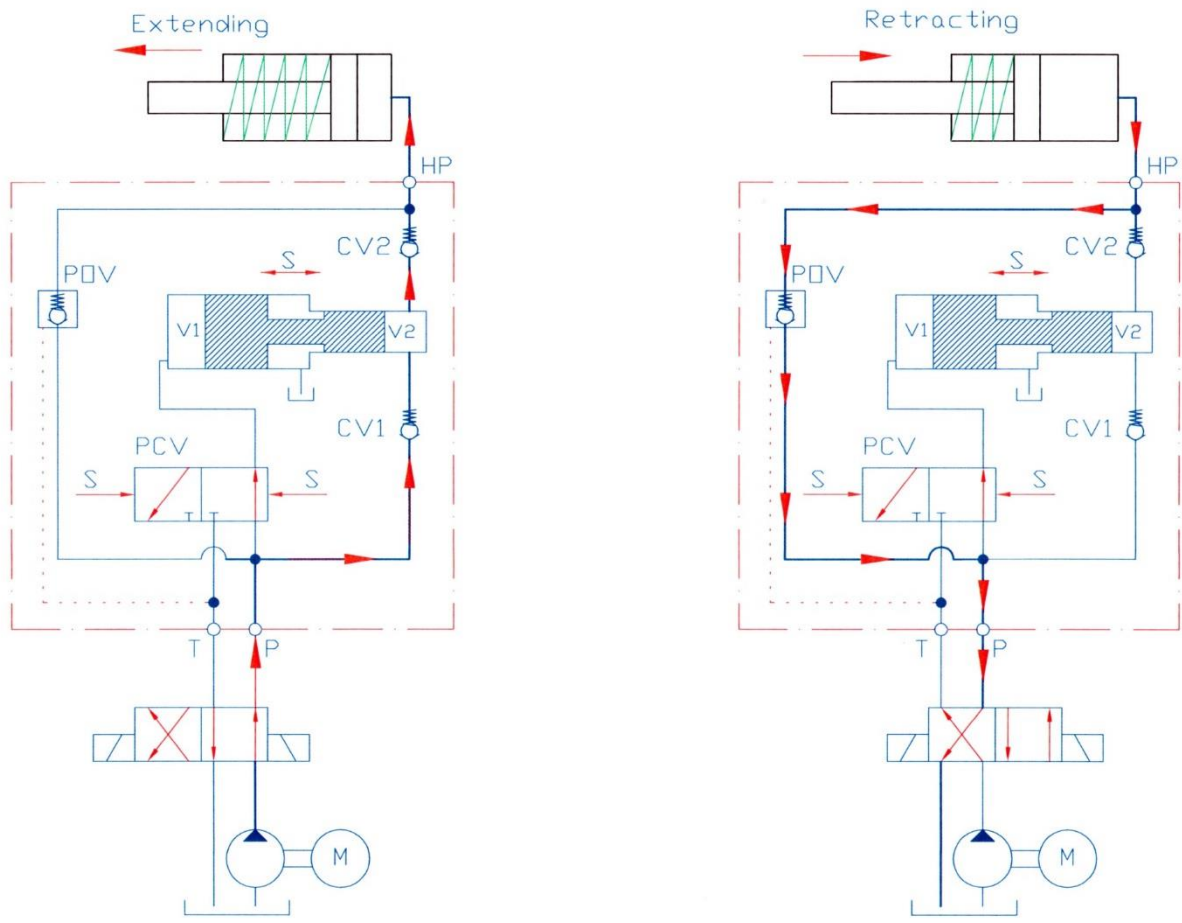



# SCANWILL INTENSIFIER PRODUCT RANGE

September 15



**MP-S: In-Line mounting**  
 P<sub>out</sub> max.: 800 bar  
 Q<sub>in</sub> max.: 8 LPM



**MP-T: In-Line mounting**  
 P<sub>out</sub> max.: 800 bar  
 Q<sub>in</sub> max.: 15 LPM



**MP-M: In-Line mounting**  
 P<sub>out</sub> max.: 800 bar  
 Q<sub>in</sub> max.: 35 LPM



**MP-L: In-Line mounting**  
 P<sub>out</sub> max.: 800 bar  
 Q<sub>in</sub> max.: 80 LPM



**MP-F: Flange-On mounting**  
 P<sub>out</sub> max.: 700 bar  
 Q<sub>in</sub> max.: 15 LPM



**MP-C: CETOP/NG6 mounting**  
 P<sub>out</sub> max.: 500 bar  
 Q<sub>in</sub> max.: 15 LPM

## SPECIAL DESIGNS:



**MP-2000: In-Line mounting**  
 P<sub>out</sub> max.: 3,000 bar  
 Q<sub>in</sub> max.: 13 LPM



**MPL-4000: In-Line mounting**  
 P<sub>out</sub> max.: 4,000 bar  
 Q<sub>in</sub> max.: 30 LPM



# SCANWILL INTENSIFIERS ACCESSORIES

September 15

## Mounting and connection kits:



Mounting brackets  
for base plate



Nut M28 x 1.5 for  
fixation



Connection kit for  
hydraulic block  
mounting

# SCANWILL INTENSIFIERS SELECTING CHART

September 15

- 1) Requested output pressure bar
- 2) Inlet flow lpm
- 3) Inlet pressure bar – to select intensifier ratio

	Pressure Intensifier Series MP - Max. Inlet Flow (lpm/gpm):									
Output Pressure (bar/psi):	MP-S	MP-T	MP-M	MP-L	MP-2000	MPL-1400	MPL-2000	MPL-4000	MP-C (Cetop)	MP-F (Flange-on)
Up to 210 bar / 3,000 psi	8.0 lpm/2.11 gpm	15.0 lpm/3.96 gpm	35.0 lpm/9.25 gpm	80.0 lpm/21.13 gpm					15.0 lpm/3.96 gpm	15.0 lpm/3.96 gpm
Up to 360 bar / 5,220 psi	8.0 lpm/2.11 gpm	15.0 lpm/3.96 gpm	35.0 lpm/9.25 gpm	80.0 lpm/21.13 gpm					15.0 lpm/3.96 gpm	15.0 lpm/3.96 gpm
Up to 500 bar / 7,250 psi	8.0 lpm/2.11 gpm	15.0 lpm/3.96 gpm	35.0 lpm/9.25 gpm	80.0 lpm/21.13 gpm					15.0 lpm/3.96 gpm	15.0 lpm/3.96 gpm
Up to 700 bar / 10,150 psi	8.0 lpm/2.11 gpm	15.0 lpm/3.96 gpm	35.0 lpm/9.25 gpm	80.0 lpm/21.13 gpm						14.0 lpm/3.70 gpm
Up to 800 bar / 11,600 psi	8.0 lpm/2.11 gpm	14.0 lpm/3.70 gpm	35.0 lpm/9.25 gpm	80.0 lpm/21.13 gpm						
Up to 1,400 bar / 20,300 psi					13.0 lpm/3.43 gpm	50.0 lpm/13.21 gpm				
Up to 2,000 bar / 29,000 psi					12.0 lpm/3.17 gpm		30.0 lpm/7.93 gpm			
Up to 2,800 bar / 40,600 psi					10.0 lpm/2.64 gpm		30.0 lpm/7.93 gpm			
Up to 3,000 bar / 43,500 psi					10.0 lpm/2.64 gpm			30.0 lpm/7.93 gpm		
Up to 4,000 bar / 60,000 psi								30.0 lpm/7.93 gpm		

# SCANWILL INTENSIFIERS TECHNICAL DATA

September 15

Material: Cast Iron & Steel (Option: Stainless Steel)

Surface Coating: Chromite Blue Finish

Minimum inlet flow:

MP-T, MP-C, MP-F & MP-2000: 2 LPM

MP-M: 7 LPM

MP-L: 15 LPM

Minimum inlet pressure: 15 bar

Temperature Range: -10 °C to 100 °C

Filtration requirement: Minimum 10 micron nominal

Fluids:

Standard hydraulic oils

Water glycol (min. 5% glycol)

Water (stainless steel units only)

Functionality test:

Factory tests – before surface coating/after surface coating



# F.A.Q. ABOUT SCANWILL INTENSIFIERS

Is the intensifier a pump?

No!

Does the T-port need to be connected?

Yes, or it will not oscillate.

Can intensifiers operate on fluid "X"?

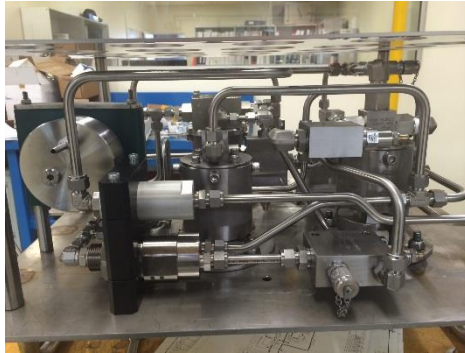

If standard hydraulic components are used - then yes! However always ask if special sealing material is required (EPDM, Viton etc.). If it is aggressive fluids check with Scanwill.

Can intensifiers be used for reducing the pressure and/or flow?

No!

Will the intensifiers operate on gas?

No!

Can the intensifiers be traced?

Yes, they are all stamped with a unique serial number.

# TROUBLESHOOTING OF SCANWILL INTENSIFIERS

Contamination in the fluid: Check valves will not close & bores will be destroyed

Too high inlet pressure: The two screws holding the body parts together will stretch and the O-rings will come out at the side. Also the BSP connections on the high pressure side must not receive more than 800 bar.

Too high inlet flow: The unit will over speed and cavitations may occur. Also the check valves will be destroyed

Too high return flow: If a relatively large volume is pressurized, and the internal POV is activated, there can for a fraction of time be a very high flow passing back through the intensifier. This may destroy the internal check valves. (Max return flow = max inlet flow!)

Air in the oil:

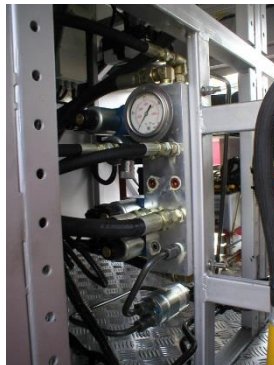

All kinds of damages can then happen ex. the valves will be destroyed.

# THE SERVICE CONCEPT FOR SCANWILL INTENSIFIERS

If a Scanwill intensifier needs service – what are your options:

Always contact Scanwill Fluid Power for advice and spare parts...

1. Separate the intensifier and clean it thoroughly. Then replace the internal check valves and o-rings
2. or return the intensifier to Scanwill Fluid Power for prompt service

Spare parts:

Valve CV1 & POV:



Valve CV2:

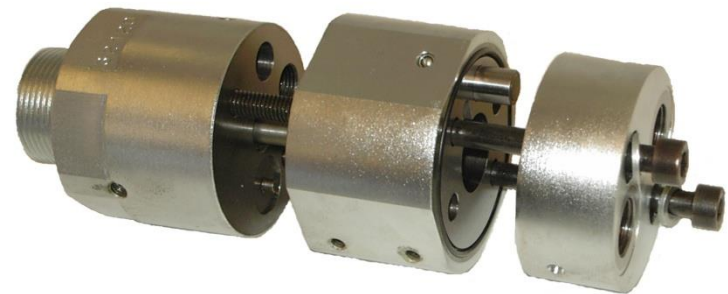

# FIRST-FIT APPLICATION: WORK HOLDING.

## OUTPUT PRESSURE: 120 – 500 BAR

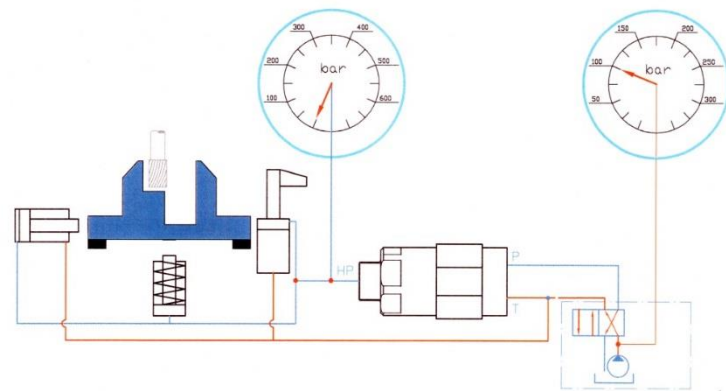
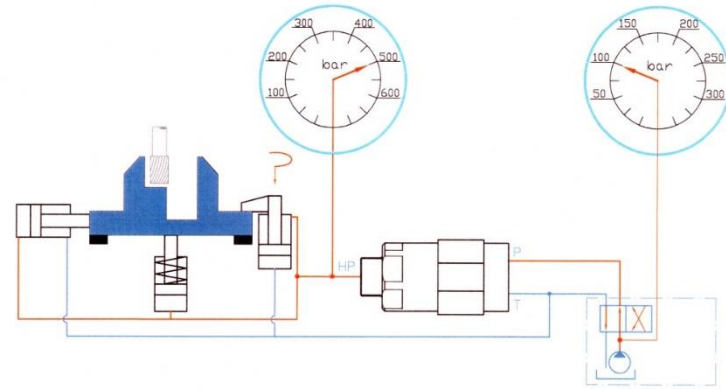
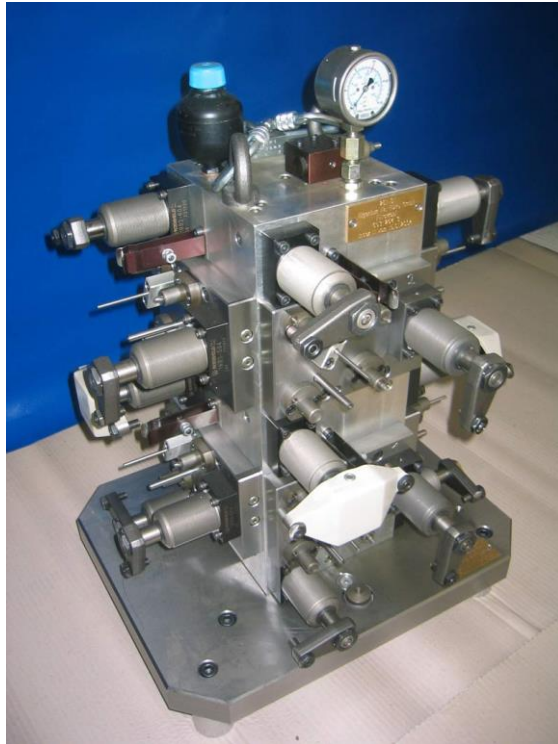

September 15



# FIRST-FIT APPLICATION: HYDRAULIC MINING EQUIPMENT. OUTPUT PRESSURE: 360 – 800 BAR

September 15



17

# FIRST-FIT APPLICATION: HYDRAULIC POWER PACKS. OUTPUT PRESSURE: 500 – 2,500 BAR

September 15

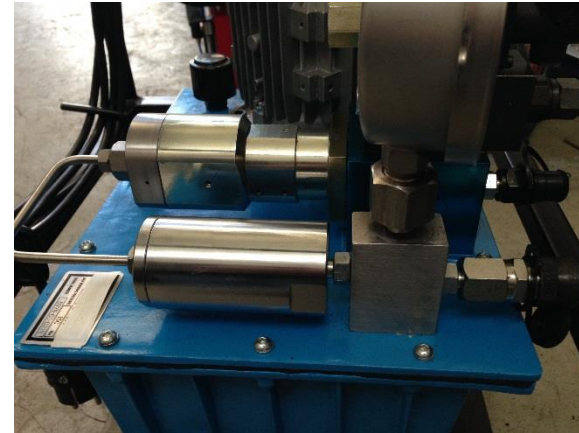
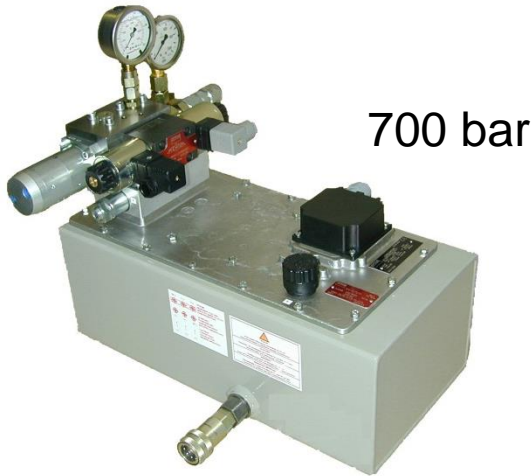

# FIRST-FIT APPLICATION: BOLT TENSIONING.

OUTPUT PRESSURE: 800 – 2,500 BAR

September 15

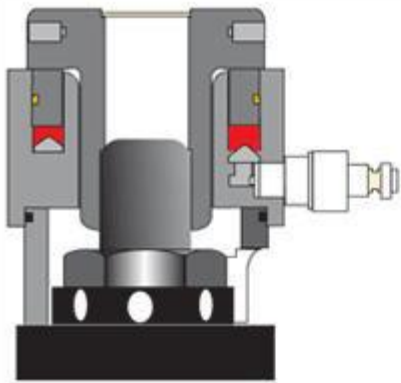

Step 1

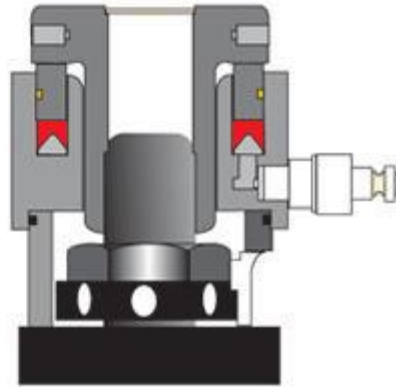

Step 2

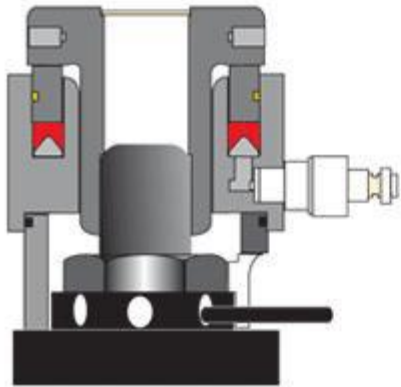

Step 3



Step 4



**HYDRAULIC**  
TENSIONING NUTS



# FIRST-FIT APPLICATION: HYDRAULIC ROUGHNECKS.

## OUTPUT PRESSURE: 500 – 700 BAR

September 15

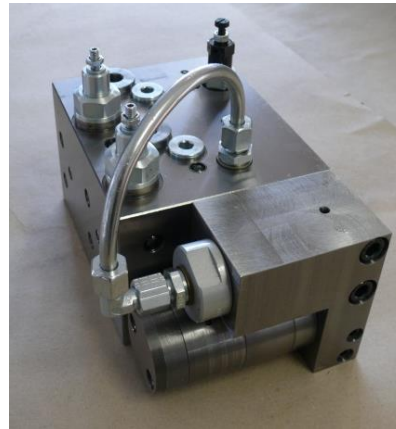

Hydraulic Blocks

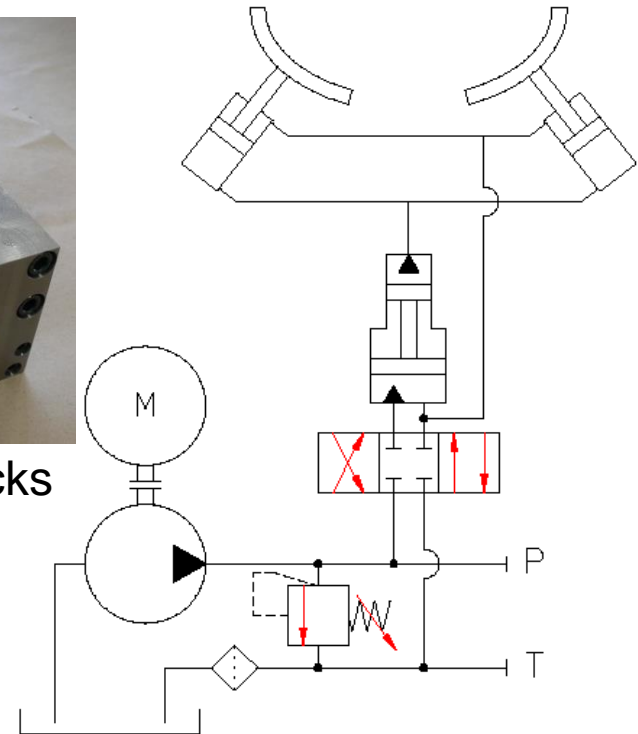

# FIRST-FIT APPLICATION: DEMOLITION TOOLS.

## OUTPUT PRESSURE: 500 – 2,800 BAR

Handheld Demolition  
Tools 500 – 700 bar



Concrete Bursting 1,500 – 2,800 bar



Excavator Tools 700 bar

# FIRST-FIT APPLICATION: FILTER PRESSES.

## OUTPUT PRESSURE: 500 – 700 BAR

September 15



Bypass circuit for high flow applications:

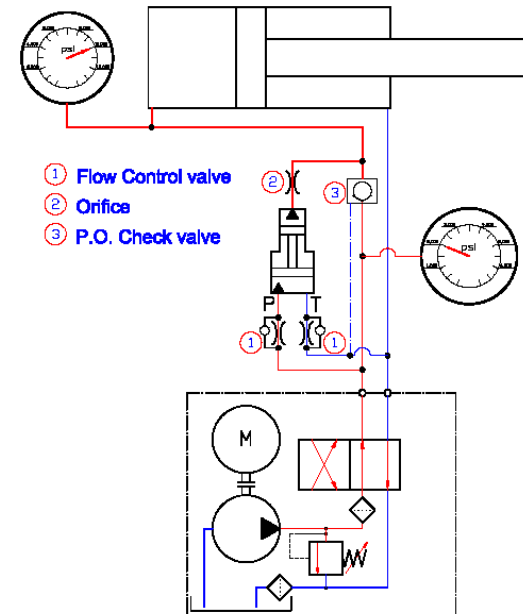

# FIRST-FIT APPLICATION: PRESSURE DIE CASTING. OUTPUT PRESSURE: 210 – 800 BAR

September 15

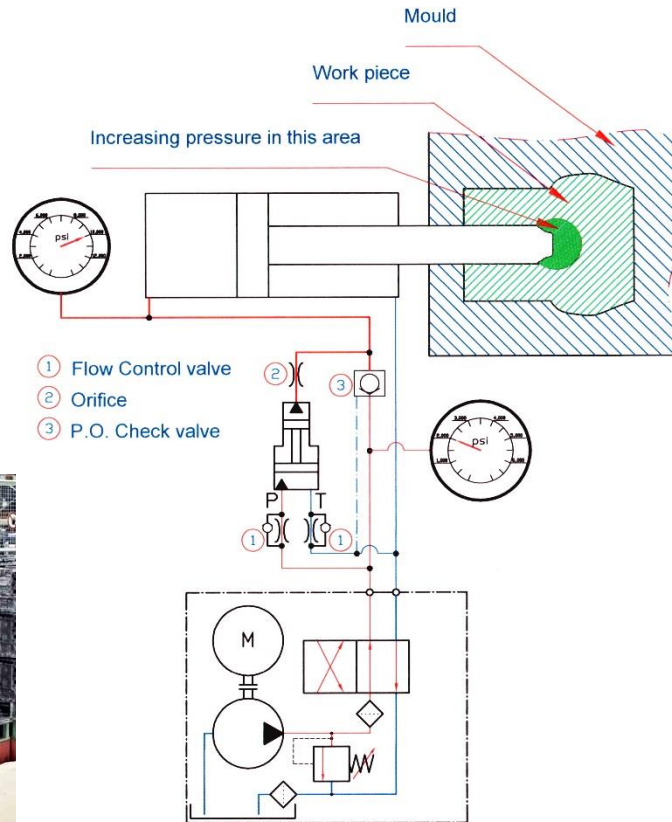
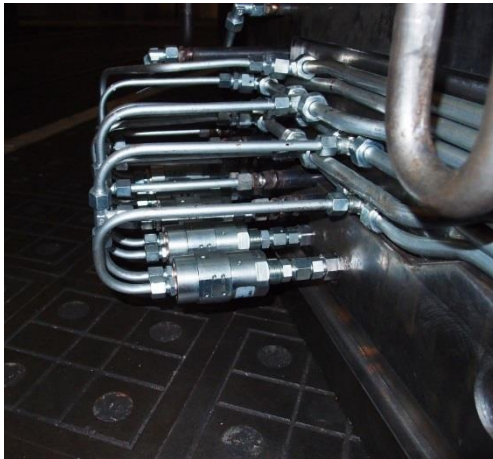

# FIRST-FIT APPLICATION: HYDRAULIC TOOLS.

## OUTPUT PRESSURE: 500 – 700 BAR

Cable Tools



Cutting Tools



ROV Tools

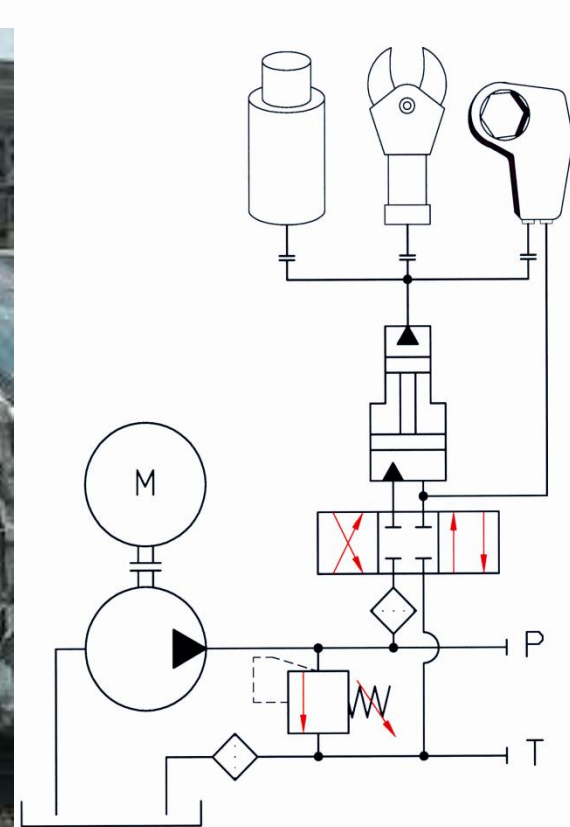

September 15

**Intensifier panels!**

24



# APPLICATION: BEARING & WHEEL ASSEMBLY

## OUTPUT PRESSURE: 2,500 – 4,000 BAR

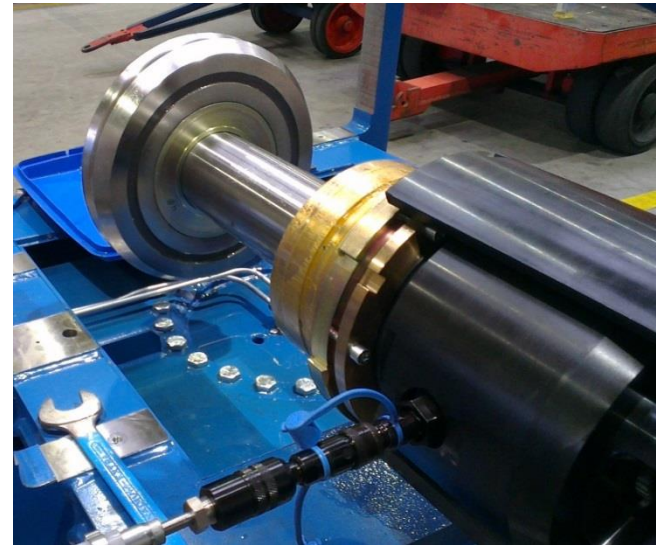
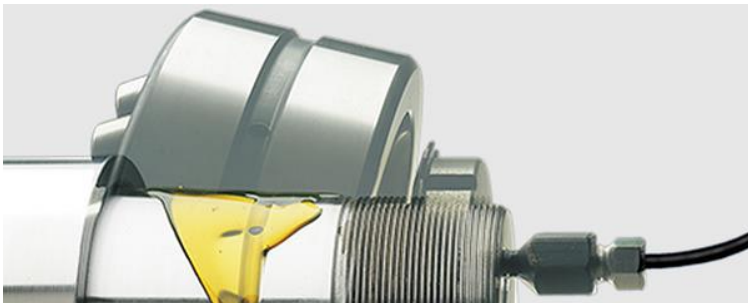
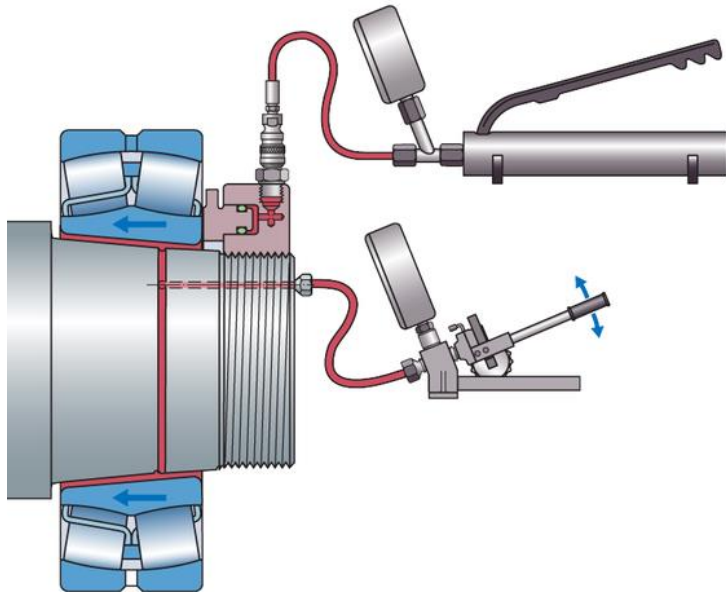

# FIRST-FIT APPLICATION: HYDRAULIC TESTING.

## OUTPUT PRESSURE: 300 – 4,000 BAR

Landing gear testing  
(A380 @12 mio. cycles)



High Pressure Testing

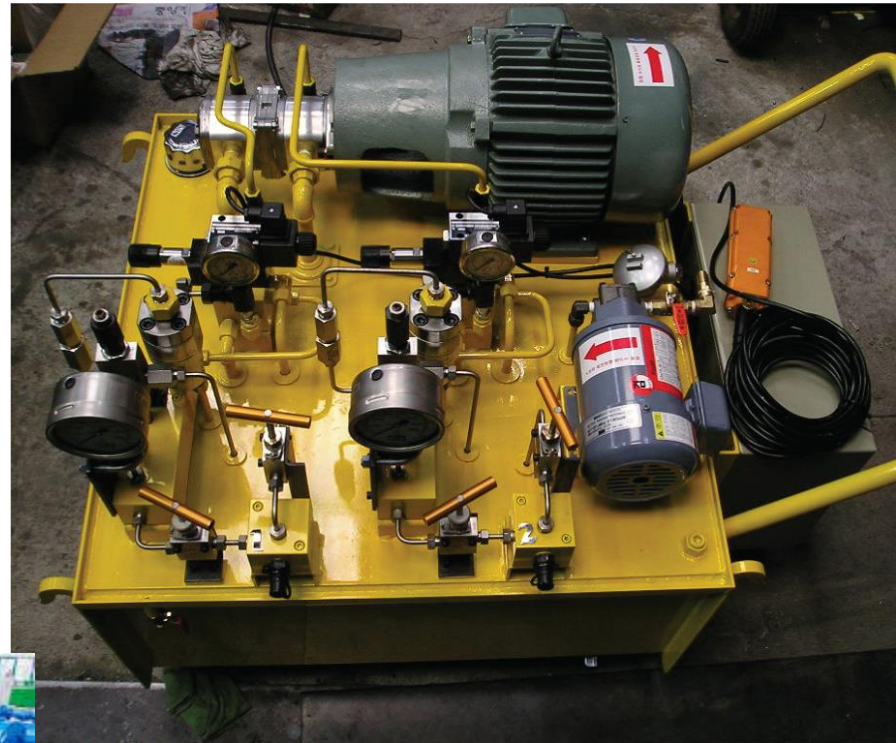

Cylinder testing



# SCANWILL INTENSIFIERS IN SHORT...

September 15

## Characteristics

- High pressure precisely where needed
- High pressure by low pressure pump
- Low pressure in most places
- Low pressure supply to intensifier
- Intensifiers are compact components
- Intensifier fitted directly to cylinder
- Just add Scanwill intensifier
- Built-in bypass valve

## Advantages

- Low operating pressure in the system
- Use existing installed pump
- Longer life of hydraulic components
- Use standard tubing, hoses & valves
- Easy to accommodate where needed
- No need for extra tubing or special parts
- Use existing equipment for the new task
- Full flow available at pump pressure

## Benefits

- Energy savings for the total system
- No need of expensive hp components
- Cost savings by maintenance
- Less cost for the total system & higher safety
- Cost savings by installation
- Cost & space savings by installation
- Cost savings by installation
- Fast operation until high pressure is reached

27

# SCANWILL INTENSIFIER – SALES CHANNELS

September 15

- **OEM (Own Equipment Manufactures)**
  - Large OEM – series production
  - Small OEM – ad hoc projects
  
- **Retro-fit at current installations**
  - Direct to end-user (ex. machine works shop, foundry)
  - Through hydraulic service/engineering company
  
- **Aftermarket**
  - Replacement of Scanwill intensifier
  - Replacement of competitor product



28

# SCANWILL FLUID POWER SUPPLY CHAIN

September 15

**All Scanwill intensifiers  
from the standard range  
are always in stock for  
day-to-day shipment!**

